

**READ THROUGH ALL INSTRUCTIONS BEFORE INSTALLATION.**

**ALWAYS WEAR PROPER SAFETY EQUIPMENT WHEN DRILLING.**

**INSTRUCTIONS WITH (\*) ONLY APPLY TO CASES WITH WHEELS.**

**RECOMMENDED TOOLS:**

- CORDLESS POWER DRILL
- PENCIL
- 1/4" DRILL BIT
- RUBBER MALLET
- 7/16" SOCKET
- SOCKET WRENCH

**STEP 1**

- (\*) REMOVE WHEEL ASSEMBLY FROM CASE BY UNSCREWING MOUNTING BOLTS (LOCATION VARIES BY CASE).
- CENTER THE PANEL INSIDE THE CASE AS PICTURED IN STEP 1.
- MARK 1/4 INCH HOLE LOCATIONS ON FLOOR OF THE CASE.
- DRILL HOLES.

**STEP 2**

- PLACE WASHER (D) OVER BOLT, NEOPRENE SIDE FACING BOTTOM OF CASE.
- INSERT BOLT (A) + WASHER (D) THROUGH HOLE IN CASE.
- GENTLY TAP BOLT (A) INTO BOTTOM OF CASE WITH MALLET.
- **RECOMMENDED METHOD:** ORIENT THE CASE AND BOLT AS PICTURED IN STEP 2.
- PLACE A SPACER OR WOOD BLOCK BETWEEN HEAD OF BOLT AND TABLE SURFACE, TO PREVENT DAMAGE TO SURFACE.
- INSTALL BOLTS ONE AT A TIME. TAP CASE WITH HAMMER OR PRESS TO DRIVE IT DOWN OVER THE BOLT (A) AND WASHER (D).
- PLACE SPACER (B) OVER BOLT (A).
- PLACE A STANDARD SOCKET OVER SPACER (B).
- GENTLY TAP SPACER (B) DOWN ONTO CARRIAGE BOLT (A), UNTIL CONTACTING THE CASE FLOOR.

**STEP 3**

- ALIGN PANEL MOUNTING HOLE WITH INSTALLED BOLT (A) AND PLACE PANEL ON TOP OF SPACER (B).
- PLACE AND SECURE NUT (C) USING SOCKET WRENCH.
- (\*) REATTACH WHEEL ASSEMBLY.

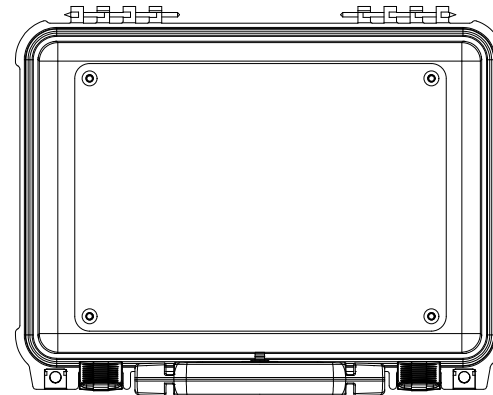

STEP 1  
(SHOWN WITHOUT LID)

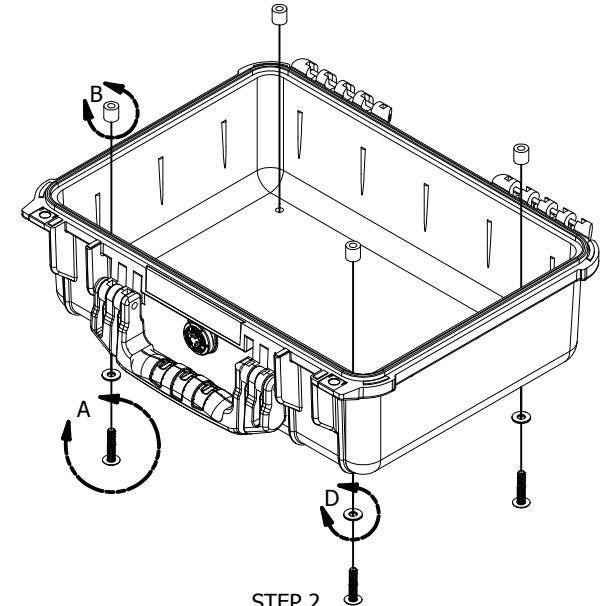

STEP 2  
(SHOWN WITHOUT LID)

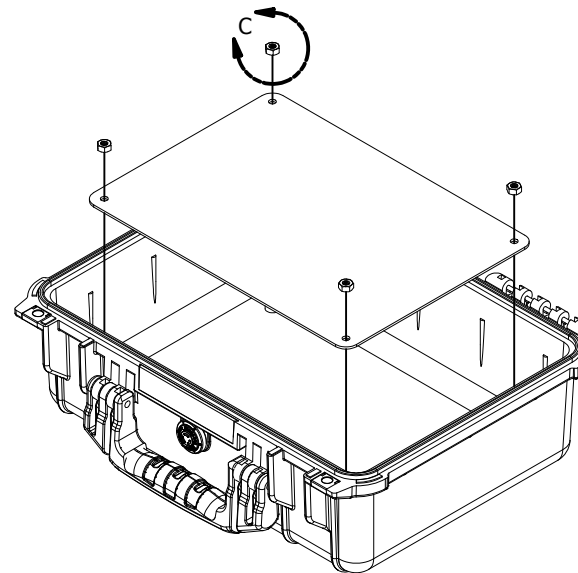

STEP 3  
(SHOWN WITHOUT LID)

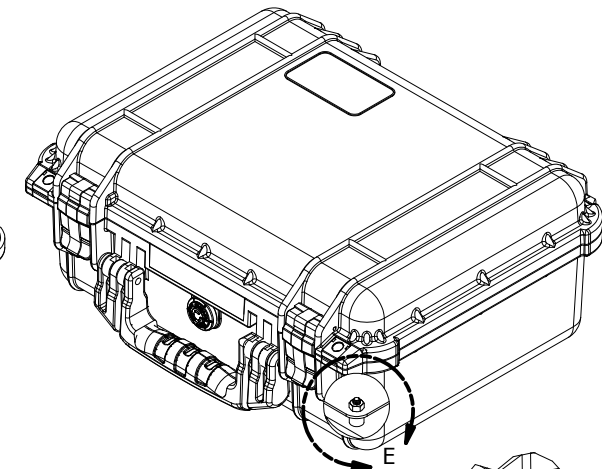

FINISH  
(WITH CUTAWAY VIEW)

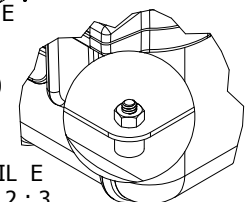

DETAIL E  
SCALE 2 : 3

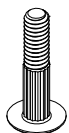

(A) = 4x  
RIBBED CARRIAGE  
BOLT 1/4"-20



(B) = 4x  
NYLON SPACER  
1/2"



(C) = 4x  
1/4"-20 NUT



(D) = 4x  
NEOPRENE BACKED  
WASHER 1/4" ID